

Northwest Corner Woodworkers Association

Volume 14 Issue 8

March, 2001

Next Meeting at John Gruenwald's Shop 2110 24th St. Anacortes October 2, 2001

September Picnic Report

Due to the events of the day, September, 11, 2001, only a small contingent of people attended the picnic at Ray's. Even though the plans that were in place did not work out, we made due with what we had and everyone enjoyed a very good meal and friendly exchange. Ray had the barbecue fired up and we barbecued a package of steaks from his fridge and some veggies from his farm.

Thanks Ray and Becky for your hospitality!

The business meeting was suspended. Judy Hemenway arrived late to talk about the show in LaConner. Evidently Stuart Hutt is interested in having it again. Firm details will be revealed later. The date is usually the first weekend in November.

Several of our members paid their dues and we have one new member, Jim Murphy. We started out the month with a bank balance of \$1304.41. I deposited dues in the amount of \$82.00, making the balance \$1386.41.

October Meeting

John is going to demonstrate sharpening. For those of you who do not know John, he is a retired tool and die maker. That qualifies him to be a pro in tool sharpening.

John asks that we bring our favorite tool sharpening tools and tricks to the meeting.

Suggested Agenda Topics

1. La Conner Show
2. Sharpening display
3. Portable bench

This Space for Rent?

Sharpening with a Flying Wedge

I was looking for a method to sharpen my plane irons that was quick, accurate and didn't remove too much metal. And I have an aversion to roller guides that are messy and push waste metal into the stone. I found the solution with this simple fixture.

Start with a hardwood board that is a couple of inches wider than your sharpening stone. Attach one track (made from a hardwood strip, 1/4 in. square) about 3/4 in. in and parallel to one edge of the board. Now place the stone against the track as it would be placed during use, and use it to mark where to attach the second track to the other edge.

Make the wedge specific to your own bevel-angle needs. The runners of the wedge must straddle both the stone and the tracks and slide freely without play. A little wax on the runners will help. To complete the fixture, attach a fence to the wedge so that the piece being sharpened will remain square to the stone. If you prefer to use two grades of stones, you can make the board long enough to hold both stones

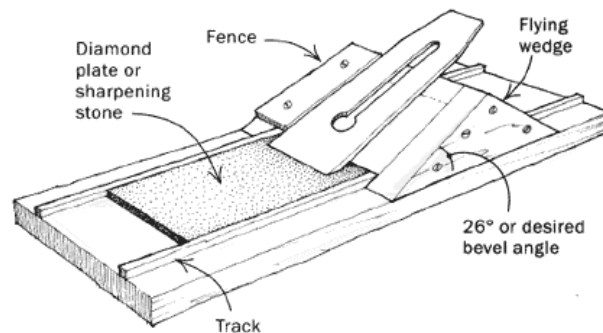

A Micro-Adjustment for the Saw Fence

This micro-adjustment fixture enables you to fine-tune the settings on a Biesemeyer-style tablesaw rip fence. The fixture consists of two main parts: a block that attaches to the cross piece of the rip fence and a clamp head that locks onto the front rail of the fence.

The adjusting device itself is a 6-in.-long, 1/2-in. carriage bolt with a wooden knob glued to its head with epoxy. The bolt runs through a slightly oversized hole in the clamp head and into a rod coupler that has been press-fit into the block. The length of the rod coupler, as opposed to a standard hex nut, helps prevent the adjusting bolt from binding as it is turned. The range of adjustment is about 1 in., more than enough for most applications.

To use the device, leave the fence-locking lever up, and then clamp the head to the fence. Twist the micro-adjustment knob as necessary to locate the fence where you want it. Then lock the fence in place with the regular locking lever. The whole setup works smoothly and is a pleasure to use.

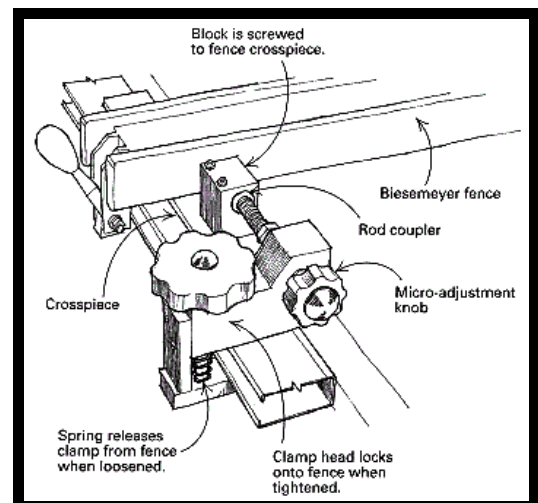

Don't forget "bring or Brag", We all do something unique or have something that others would enjoy seeing.

Information provided by Gary. You must have Internet access.

Timbershop.com
Brigadoon, LLC PO Box 746088

- \$25 annual membership
- Woodworkers can list as many items as they choose
- Up to three pictures of each item
- No limit on picture size or quality
- Up to a 50 word description
- You set the price
- Hardly any computer skills needed
- We send you a pre-paid, pre-addressed Shipping label for each item
- Member Area with Bulletin Board

Pros and Cons

Frequently Asked Questions

Have a Question

Membership Form

- After proof of shipment we send a check less a 20% commission
- You can change the price of an item at any time
- You can remove an item at any time
- If an item is unique it cannot be for sale anywhere else
- Two types of products can be sold at Timbershop.com
- For information on what happens when an item is purchased
- Customers can search by artisan's name

Directions to John's Shop

Take the Highway 20 exit from I-5, proceed to Anacortes, Turn right on commercial St., then left on 32nd St., proceed to 24th St., turn right. John's house is towards the end of the cul-de-sac on the left.

2110 24th St.

Jake Strauss

Kiln dried NW Washington hardwood lumber. (Sales by appointment only)
6389 North Star Rd.
Ferndale, WA 98248
(360)384-3948

The NCWA was formed to promote high standards in woodworking, woodworking education, and showcasing local woodworking. The NCWA is open to all interested woodworkers.. Dues are \$24 per year, payable to NCWA, 7550 Ershig Rd. Bow, Wa. 98232. Newsletter submissions are welcomed and are due by the 18th of the month to NCWA Newsletter, 925 South Hills Dr. Bellingham, Wa., 98226. Or call (360) 734-9473. Meetings are held on the first Tuesday of each month at 7:00 P.M. Location announced in the newsletter

2000-20001 Officers:

President	Gary Holloman	(360) 855-3376
VP	Jim Fox	(360) 647-7039
Sec.	Vacant	(360) 000-0000
Treas.	Laura Matthews	(360) 757-7730
Library	Tom Chartier	(360) 734-9473
Programs	Larry Tomovick	(360) 293-4580
Editor	Tom Chartier	(360) 734-9473

NCWA Newsletter
 925 South Hills Dr
 Bellingham Wa. 98226.

